



KINDLY MOTOR

PMDC Geared Motor

KC38-3625G Series

| | |
|-----------------|---|
| Bearings | Sleeve |
| Number of poles | 3 or 5 |
| Brush Type | Carbon |
| EMC Suppression | Internal Disk Varistor, Internal Capacitor (optional) |
| Gear Type | Metal |

| Model | Gear Ratio |
|-------|------------|
| G10 | 1:10 |
| G31 | 1:31 |
| G43 | 1:43 |
| G109 | 1:109 |

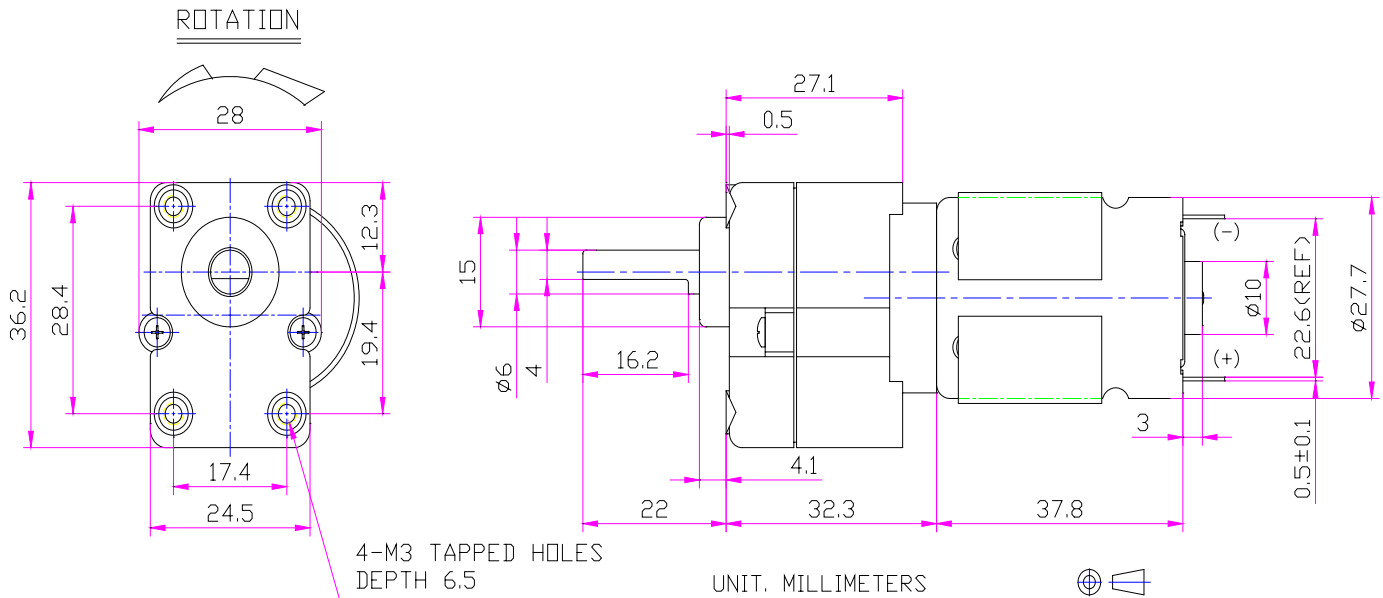

| Model | Voltage | | No Load | | Rated Load | | | | Stall | Max. Rated Tolerance Torque | Momentary Tolerance Torque |
|------------------------|----------------------|-----------------------|--------------|---------------|--------------|---------------|-----------------|-------------|-----------------|-----------------------------------|----------------------------------|
| | Operating Voltage | Nominal (Constant) | Speed rpm | Current A. | Speed rpm | Current A. | Torque kg-cm | Output W | Torque kg-cm | | |
| KC38-3625G10-13 | 12.0-30.0 | 24.0 | 530.0 | 0.110 | 412.2 | 0.374 | 1.00 | 4.230 | 4.50 | 2.5 | 10.0 |
| KC38-3625G10-19 | 6.0-15.0 | 12.0 | 540.0 | 0.120 | 420.0 | 0.693 | 1.00 | 4.310 | 4.50 | 2.5 | 10.0 |
| KC38-3625G31-10 | 12.0-30.0 | 24.0 | 130.0 | 0.070 | 100.0 | 0.204 | 1.50 | 1.540 | 6.50 | 2.5 | 10.0 |
| KC38-3625G31-16 | 6.0-18.0 | 12.0 | 158.0 | 0.120 | 120.8 | 0.539 | 2.00 | 2.480 | 8.50 | 3.5 | 10.0 |
| KC38-3625G43-12 | 6.0-30.0 | 24.0 | 129.0 | 0.080 | 99.2 | 0.338 | 3.00 | 3.050 | 13.00 | 5.0 | 15.0 |
| KC38-3625G109-14 | 9.0-30.0 | 19.0 | 51.0 | 0.065 | 41.9 | 0.330 | 5.00 | 2.150 | 28.00 | 8.0 | 15.0 |
| KC38-3625G109-14 | 9.0-30.0 | 29.0 | 78.5 | 0.085 | 69.8 | 0.326 | 5.00 | 3.580 | 45.00 | 8.0 | 15.0 |
| KC38-3625G109-14 | 9.0-30.0 | 24.0 | 65.0 | 0.080 | 56.0 | 0.333 | 5.00 | 2.870 | 36.00 | 8.0 | 15.0 |
| General Test Tolerance | | | ±15% | | | | | | | | |

Typical Application: Vending Machines, Automation Equipments, Precision Instruments and More...